

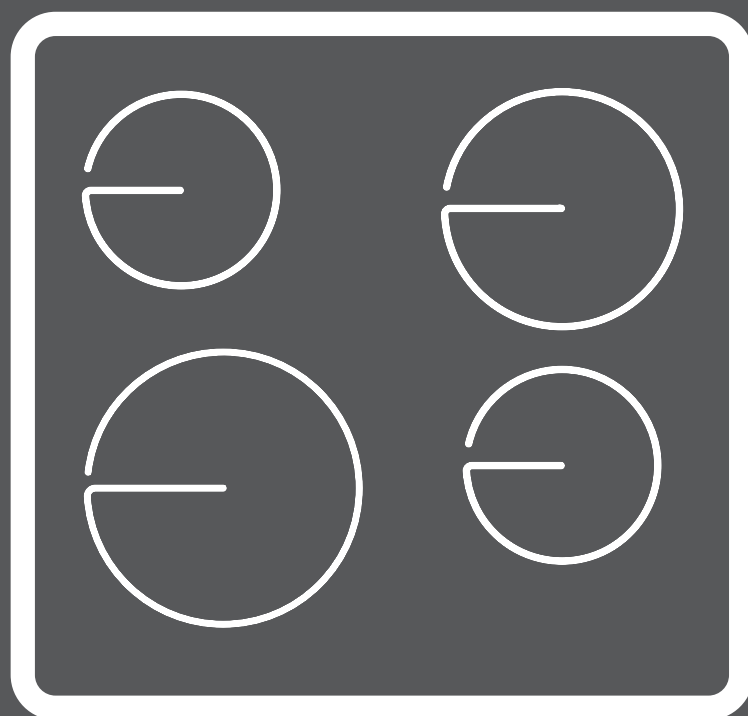

CERAMIC COOKTOP

User Manual



MODEL

CHC644BB

Congratulations

Congratulations and thank you for choosing our Ceramic Cooktop. We are sure you will find your new appliance a pleasure to use and a great asset to your cooking. Before you use the appliance, we recommend that you read through the whole user manual which provides a description of the product and its functions.

To avoid the risks that are always present when you use a cooking appliance, it is important that the appliance is installed correctly and that you read the safety instructions carefully to avoid misuse and hazards. For future reference, please store this booklet in a safe place. This appliance complies to the requirements of Australian Standard AS4551.

Conditions of use

This appliance is intended to be used in household and similar applications such as:

- Staff kitchen areas in shops, offices and other working environments
- Farm houses
- By clients in hotels, motels and other residential type environments
- Bed and breakfast type environments

Record model and serial number here:

Model:.....

Serial number:

The symbols you will see in this booklet have these meanings:

WARNING

Indicates information concerning your personal safety

CAUTION

Indicates information on how to avoid damaging the appliance

IMPORTANT

Indicates tips and information about use of the appliance

ENVIRONMENTAL TIPS

Indicates tips and information about economical and ecological use of the appliance

IMPORTANT

Important – check for any damage or marks

If you find the appliance is damaged or marked, you must report it within 7 days if you wish to claim for damage/marks under the manufacturer's warranty. This does not affect your statutory rights.

ENVIRONMENTAL TIPS

Information on disposal for users

- Most of the packing materials are recyclable. Please dispose of those materials by contacting your local authorities and ask for the correct method of disposal.

CONTENTS

General safety	3
Description of the Appliance	4
Daily use	6
Tips on Cooking and Frying	7
Energy Saving	7
Cleaning and Care	8
Troubleshooting	9
Installation Instructions	10
Electrical connection	10
Assembly	11
Disposal	14
Technical Data	14
Warranty	15
Service	15

general safety

CAUTION

**Please comply with these instructions.
If you do not, any damage resulting is not covered by the warranty.**

General safety

- This appliance may only be installed and connected by trained, registered service engineers.
- Built-in appliances may only be used after they have built-in units and work surfaces that meet standards.
- In the event of faults with the appliance or damage to the glass ceramic (cracks, scratches or splits), the appliance must be switched off and disconnected from the electrical supply, to prevent the possibility of an electric shock.
- Repairs to the appliance must only be carried out by trained registered service engineers.

Children's safety

- The cooking zones will become hot when you cook. Therefore, always keep small children away from the appliance.
- The appliance is not intended for use by persons (including children) with reduced physical, sensory or mental capabilities, or lack of experience and knowledge, unless they have been given supervision or instruction concerning use of the appliance by a person responsible for their safety.
- Children should be supervised to ensure that they do not play with the appliance.

Correct use

- This appliance should be used only for normal domestic cooking and frying of food.
- The appliance must not be used as a work surface or as a storage surface.
- Additions or modifications to the appliance are not permitted.
- Do not place or store flammable liquids, highly inflammable materials or fusible objects (e.g. plastic film, plastic, aluminium) on or near the appliance.

Safety during use

- Remove stickers and film from the glass ceramic.
- There is the risk of burns from the appliance if used carelessly.
- Cables from electrical appliances must not touch the hot surfaces of the appliance or hot cookware.
- Overheated fats and oils can ignite very quickly. When cooking with fat or oil (e.g. Chips) do not leave the appliance unattended.
- Switch the cooking zones off after each use.

Safety when cleaning

- For cleaning, the appliance must be switched off and cooled down.
- For safety reasons, the cleaning of the appliance with steam jet or high pressure cleaning equipment is not permitted.

How to avoid damage to the appliance

- The glass ceramic can be damaged by objects falling onto it.
- The edge of the glass ceramic can be damaged by being knocked by the cookware.
- Cookware made of cast iron, cast aluminum or with damaged bottoms can scratch the glass ceramic if pushed across the surface.
- Objects that melt and things that boil over can burn onto the glass ceramic and should be removed straightaway.
- To avoid damaging cookware and glass ceramics, do not allow saucepans or frying pans to boil dry.
- Do not use the cooking zones with empty cookware or without cookware.

description

CHC644BB

Cooking surface layout

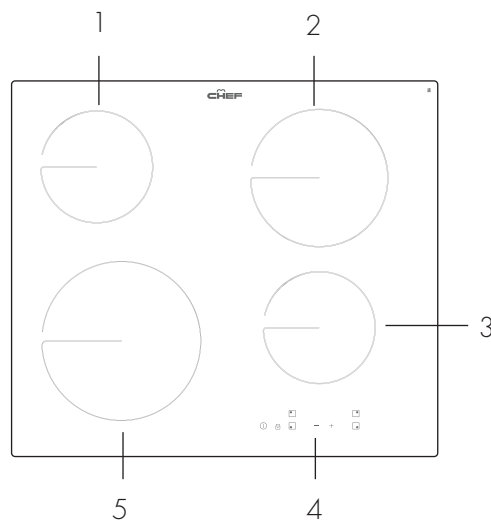



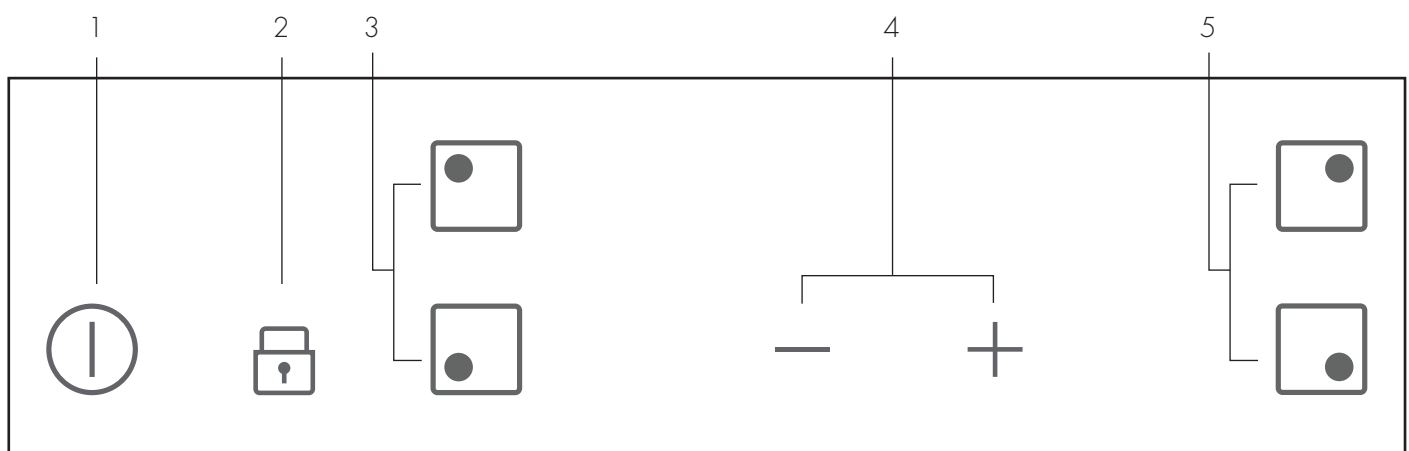



- 1 Cooking zone
- 2 Cooking zone
- 3 Cooking zone
- 4 Control panel
- 5 Cooking zone



Use the sensor fields to operate the appliance. The displays and indicators tell which functions operate.

	SENSOR FIELD	FUNCTION
1	ⓘ	Activates and deactivates the appliance
2	🔒	Locks/unlocks the control panel
3	◻ ◻	Activates the cooking zone
4	- +	Increases and decreases the heat settings
5	◻ ◻	Activates the cooking zone

Heat setting displays

DISPLAY	DESCRIPTION
	The cooking zone is deactivated.
	The cooking zone operates.
	There is a malfunction.
	A cooking zone is still hot (residual heat).
	The Automatic Switch Off function operates.
	The Lock/the child safety device is in operation

Residual heat indicator

WARNING

 The risk of burns from residual heat!

daily use

Activation and deactivation

Touch **1** for 1 second to activate or deactivate the appliance.

Automatic Switch Off

The function deactivates the appliance automatically if:

- All cooking zones are deactivated (**0**).
- You do not set the heat setting after you activate the appliance.
- You spill something or put something on the control panel for more than 10 seconds, (a pan, a cloth, etc.). Remove the object or clean the control panel.
- You do not deactivate a cooking zone or change the heat setting. After some time **0** comes on and the appliance deactivates. See below.
- The relation between heat setting and times of the Automatic Switch Off function:
 - **1** - **2** — 6 hours
 - **3** - **4** — 5 hours
 - **5** — 4 hours
 - **6** - **9** — 1.5 hours

The cooking zone selection

To set the cooking zone touch the sensor field **0** related to this zone. The display highlights the heat setting indication (**0**).

The heat setting

Set the cooking zone. Touch **+** to increase the heat setting. Touch **-** to decrease the heat setting. The display shows the heat setting. Touch **+** and **-** at the same time to deactivate the cooking zone.

Lock

When the cooking zones operate you can lock the lock control panel, but not **1**. It prevents an accidental change of the heat setting. First set the heat setting. To start this function **0**. The **L** symbol comes on for 4 seconds.

To stop this function **0**. The heat setting that you set before comes on. When you switch off the cooktop, you also stop this function.

The child safety device

This function prevents an accidental operation of the appliance. To activate the child safety device:

- Activate the appliance with **1**. Do not set the heat settings.
- Touch **0** for 4 seconds. The symbol **L** comes on.
- Deactivate the appliance with **1**.

To deactivate the child safety device:

- Activate the appliance with **1**. Do not set the heat settings. Touch **0** for 4 seconds. The symbol **0** comes on.
- Deactivate the appliance with **1**.

To override the child safety device for only one cooking time:

- Activate the appliance with **1**. The symbol **L** comes on.
- Touch **0** for 4 seconds. Set the heat setting for 10 seconds. You can operate the appliance.
- When you deactivate the appliance with **1**, the child safety device operates again.

cooking and frying

i IMPORTANT

According to the latest scientific knowledge, intensive browning of food, especially in products containing starch, can constitute a health risk due to acrylamides. Therefore we recommend cooking at the lowest possible temperatures and not browning foods too much.

Cookware

The residual heat indicator lights up, as soon as the corresponding zone is hot.

energy saving

🌿 ENVIRONMENTAL TIPS

Always place cookware on the cooking zone before it is switched on.

If possible, always place lids on the pans.

Switch cooking zones off before the end of the cooking time, to take advantage of residual heat.

Bottom of pans and cooking zones should be the same size.

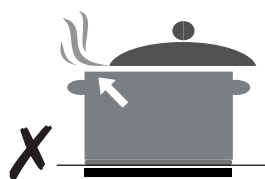

Incorrect setting.

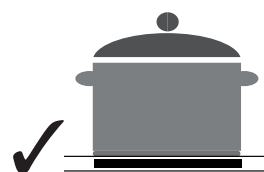

Correct setting.

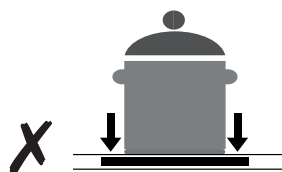

For a small cooking zone, use a small utensil.

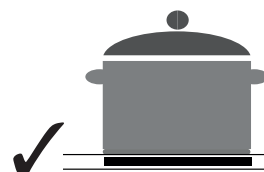

For a large cooking zone, use a large utensil.

cleaning and care

WARNING

Risk of burns from residual heat.

WARNING

Sharp objects and abrasive cleaning materials will damage the appliance. Clean with water and washing up liquid.

WARNING

Residues from cleaning agents will damage the appliance. Remove residues with water and washing up liquid.

Cleaning the appliance after each use

1. Wipe the appliance with a damp cloth and a little washing up liquid.
2. Rub the appliance dry using a clean cloth.

Removing deposits

1. Place a scraper on the glass ceramic surface at an angle.
2. Remove residues by sliding the blade over the surface.
3. Wipe the appliance with a damp cloth and a little washing up liquid.
4. Rub the appliance dry using a clean cloth.

TYPE	REMOVE		
	IMMEDIATELY	AFTER COOLING	USE
Sugar, food containing sugar	yes	–	a scraper*
Plastics, tin foil	yes	–	a scraper*
Limescale and water rings	–	yes	cleaner for glass ceramic or stainless steel*
Fat splashes	–	yes	cleaner for glass ceramic or stainless steel
Shiny metallic discolouration	–	yes	cleaner for glass ceramic or stainless steel



* Scrapers and cleaners for glass and stainless steel can be purchase in specialist shops.

IMPORTANT

Remove stubborn residues with a cleaner for glass ceramic or stainless steel.

Scratches or dark stains on the glass ceramic that cannot be removed do not however affect the functioning of the appliance.

troubleshooting

PROBLEM	POSSIBLE CAUSE	REMEDY
You cannot activate the appliance or operate it.	The appliance is not connected to an electrical supply or it is connected incorrectly.	Check if the appliance is correctly connected to the electrical supply (refer to connection diagram).
		Activate the appliance again and set the heat setting in less than 10 seconds.
	You touched 2 or more sensor fields at the same time.	Touch only one sensor field.
	There is water or fat stains on the control panel.	Clean the control panel.
The appliance deactivates.	You put something on the sensor field  .	Remove the object from the sensor field.
The residual heat indicator does not come on.	The cooking zone is not hot because it operated only for a short time.	If the cooking zone operated sufficiently long to be hot, speak to the service centre.
The sensor fields become hot.	The cookware is too large or you put it too near to the controls.	Put large cookware on the rear cooking zones if necessary.
comes on.	The Automatic Switch Off operates.	Deactivate the appliance and activate it again.
and a number come on.	There is an error in the appliance.	Disconnect the appliance from the electrical supply for some time. Disconnect the fuse from the electrical system of the house. Connect it again. If  comes on again, speak to the service centre.

If you tried the above solutions and cannot repair the problem, speak to your dealer or the customer service. Give the data from the rating plate, and an error message that comes on.

Make sure, you operated the appliance correctly. If not the servicing by a customer service technician or dealer will not be free of charge, also during the warranty period. The instructions about the customer service and conditions of guarantee are in the guarantee booklet.

installation

Safety instructions

The laws, ordinances, directives and standards in force in the country of use are to be followed (safety regulations, proper recycling in accordance with the regulations, etc.)

Installation may only be carried out by a qualified electrician. The minimum distances to other appliances and units are to be observed. Anti-shock protection must be provided by the installation, for example drawers may only be installed with a protective floor directly underneath the appliance. The cut surfaces of the workshop are to be protected against moisture using a suitable sealant. The sealant seals the appliance to the worktop with no gap. Avoid installing the appliance next to doors and under windows. Otherwise hot cookware may be knocked off the rings when doors are opened.

WARNING

Risk of injury from electrical current.

- The electrical mains terminal is live.
- Make electrical mains terminal free of voltage.
- Observe connection schematic.
- Observe electrical safety rules.
- Ensure anti-shock protection through correct installation by a qualified electrician.
- The appliance must be connected to the electrical supply by a qualified electrician.

WARNING

Risk of injury from electrical current.

Loose and inappropriate plug and socket connections can make the terminal overheat.

- Have the clamping joints correctly installed by a qualified electrician.
- Use strain relief clamp on cable.
- **CAUTION:** The surface temperature exceeds 95°C. To avoid a hazard, underbench access must be restricted.
- Supply cords must have a temperature rating not less than 105°C.

electrical connection

Before connecting, check that the nominal voltage of the appliance, that is the voltage stated on the rating plate, corresponds to the available supply voltage.

The rating plate is located on the lower casting of the hob.

The heating element voltage is AC230V~. The appliance also works perfectly on networks with AC220V~ or AC240V~.

The hob is to be connected to the mains using a device that allows the appliance to be disconnected from the mains at all poles with a contact opening width of at least 3mm, e.g. automatic line protecting cut-out, earth leakage trips or fuse. A cable with minimum temperature rating of V90HT or one with a higher grade must be used as the mains connecting cable. The connection must be carried out as shown in the diagram. The connecting links should be fitted according to the appropriate connection diagram. The earth lead must be longer than leads carrying electric current.

The cable connections must be made in accordance with regulations and the terminal screws tightened securely.

Finally, the connecting cable is to be secured with the mains cable cleat and the covering closed by pressing firmly (lock into place). Before switching on for the first time, any protective foil or stickers must be removed from the glass ceramic surface.

CAUTION

Once connected to the mains supply check that all cooking zones are ready for use by briefly switching each on in turn at the maximum setting.

Sticking on the seal

- Clean the worktop around the cutout area.
- Stick the single-sided adhesive sealing tape provided on the underside of the hob around the outside edge ensuring that it is not stretched. The two ends of the tape should join in the middle of one side. After trimming the tape (allow it to overlap by 2–3mm), press the two ends together.

IMPORTANT

The cut-out section in the worktop is illustrated in the drawing with the dimensions 560 x 490 / 880 x 490mm. The appliance can also be built into a shorter cut-out section with the dimensions 560 x 485 / 880 x 485 mm.

assembly

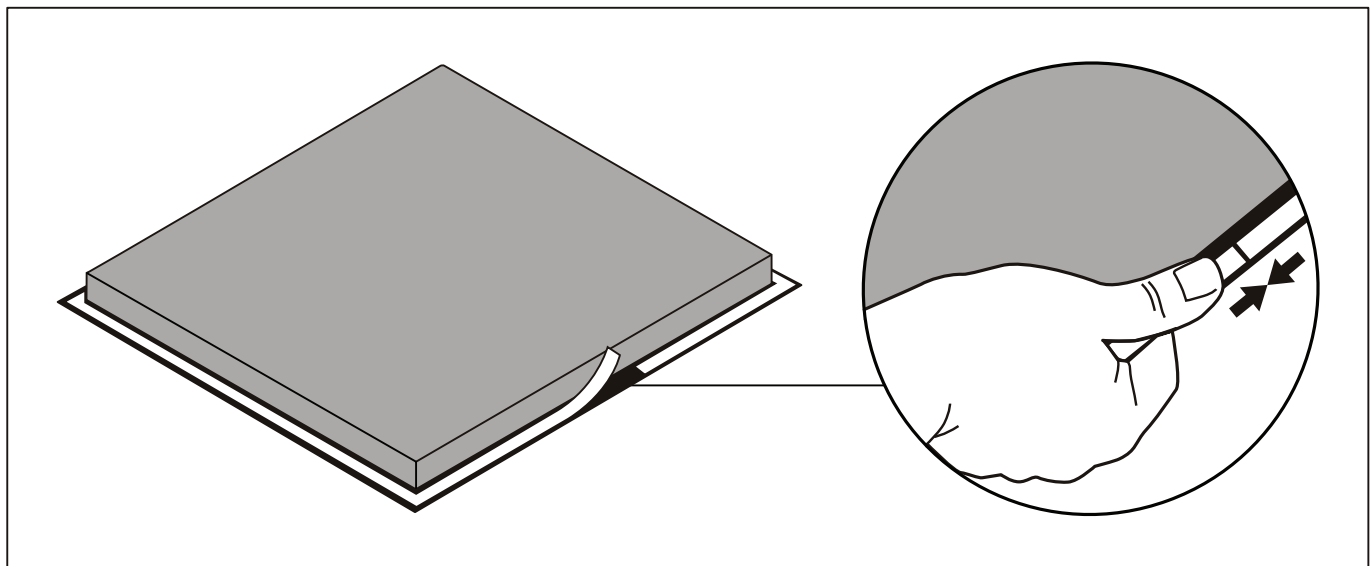
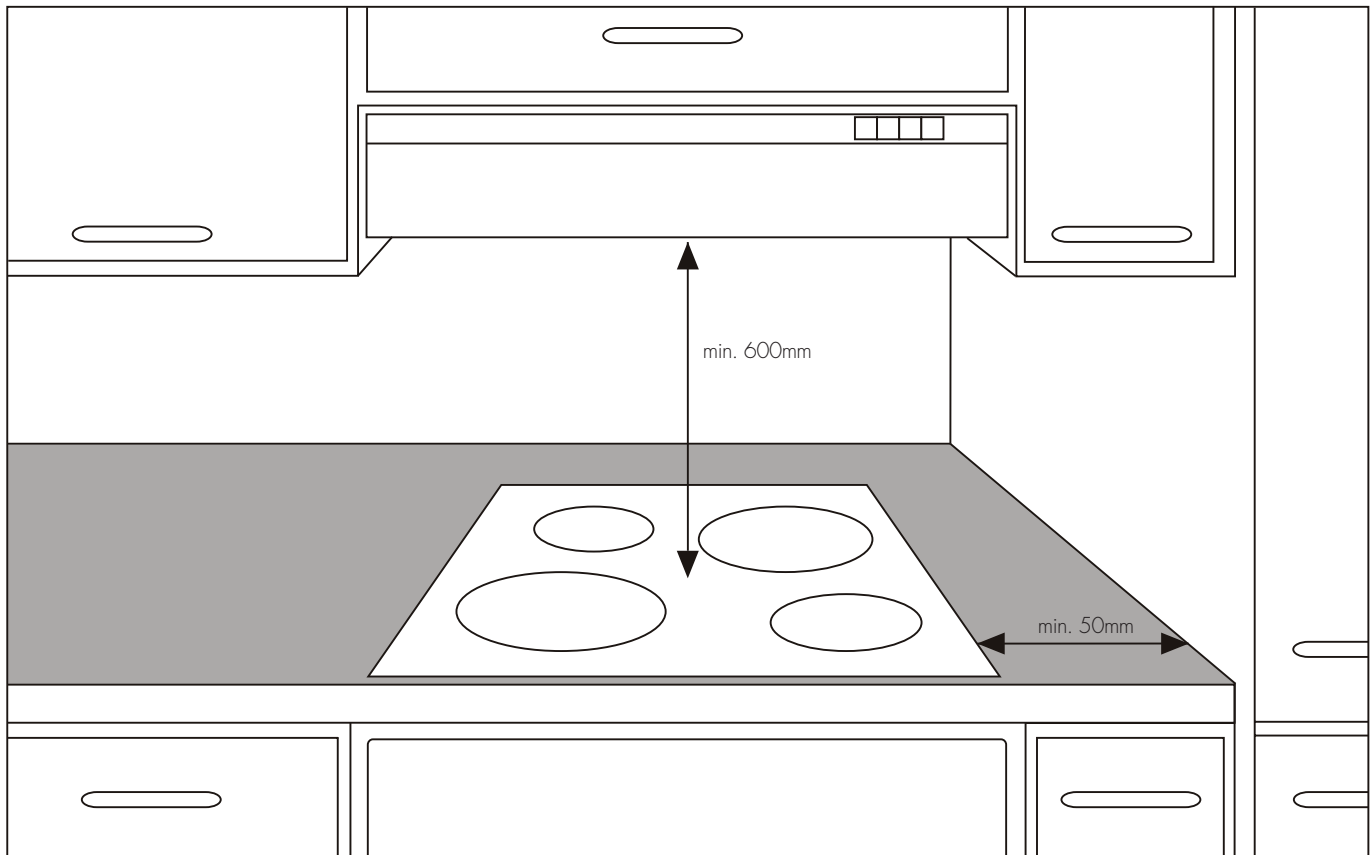

assembly

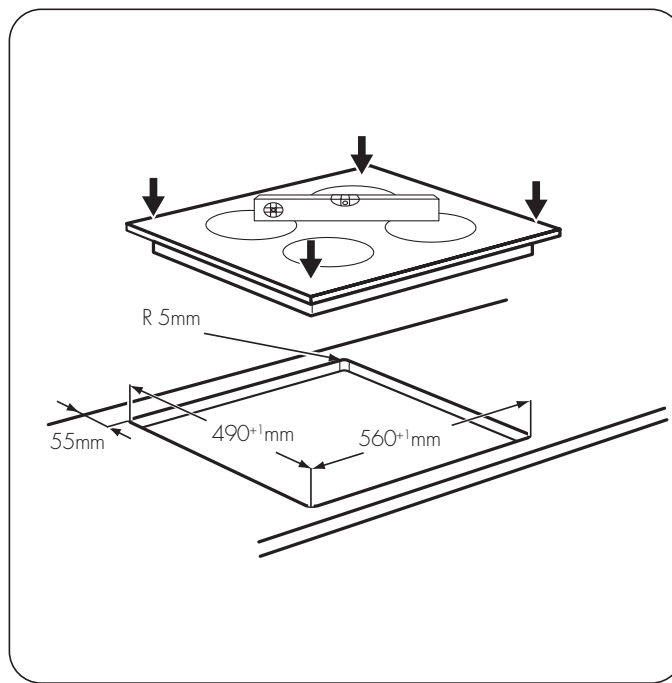
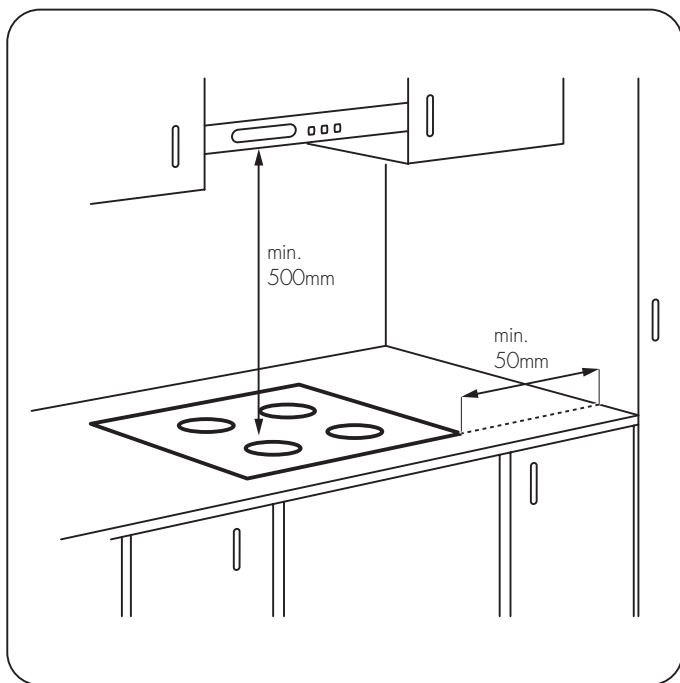

Installation above cupboards or drawers

Under hob access must be restricted by the addition of a board mounted at least 20mm from underside of hob.

Installation above cupboards or drawers

Under hob access must be mounted at least 20mm from top of appliance.

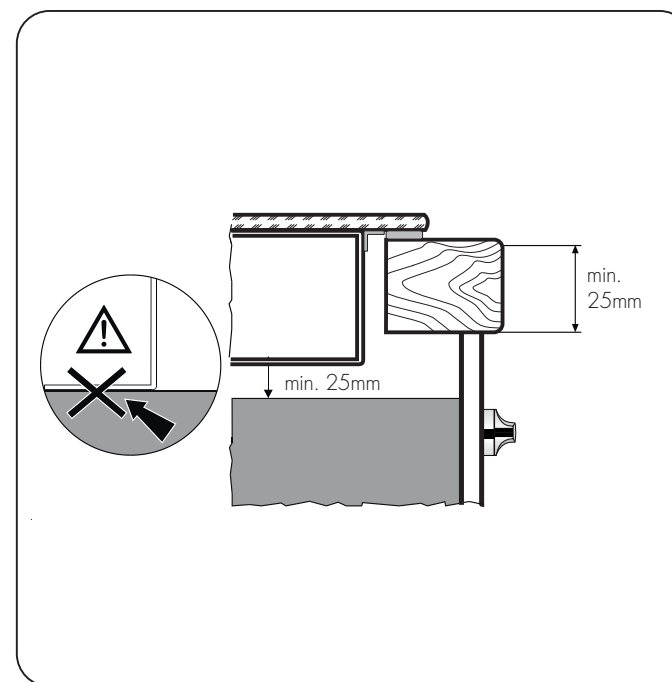
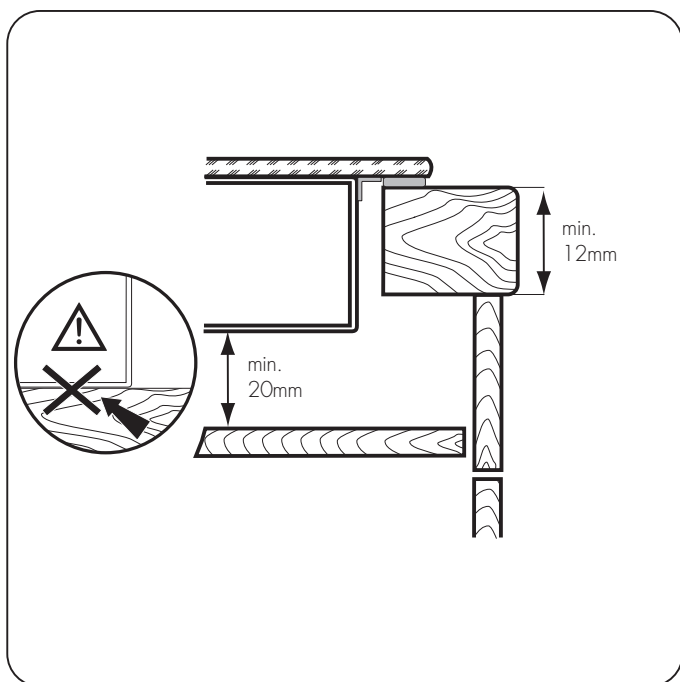

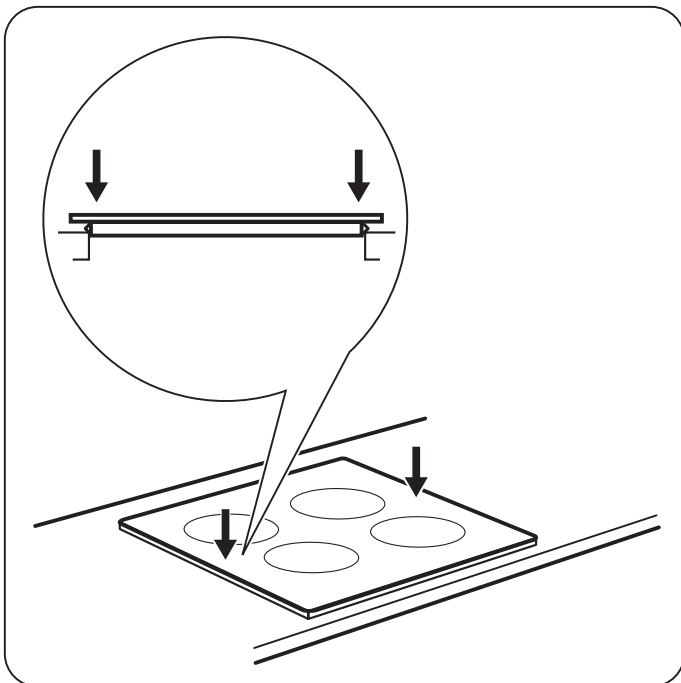
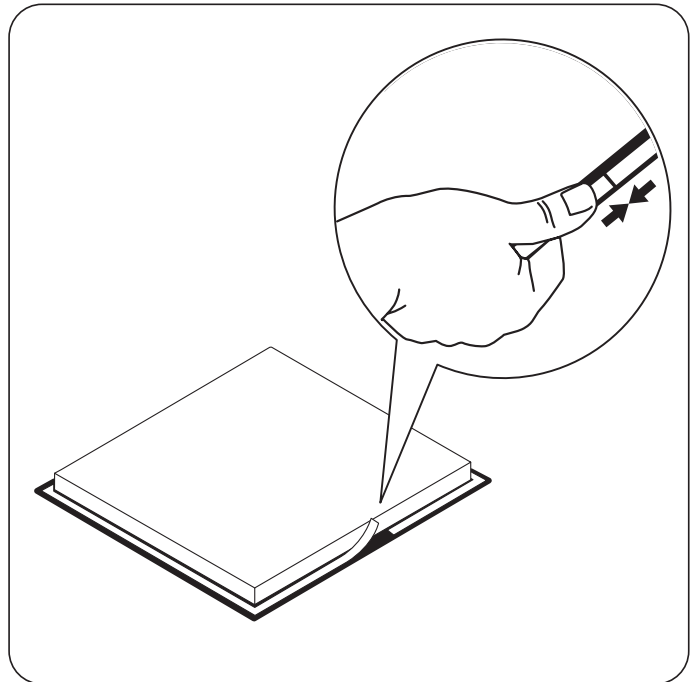
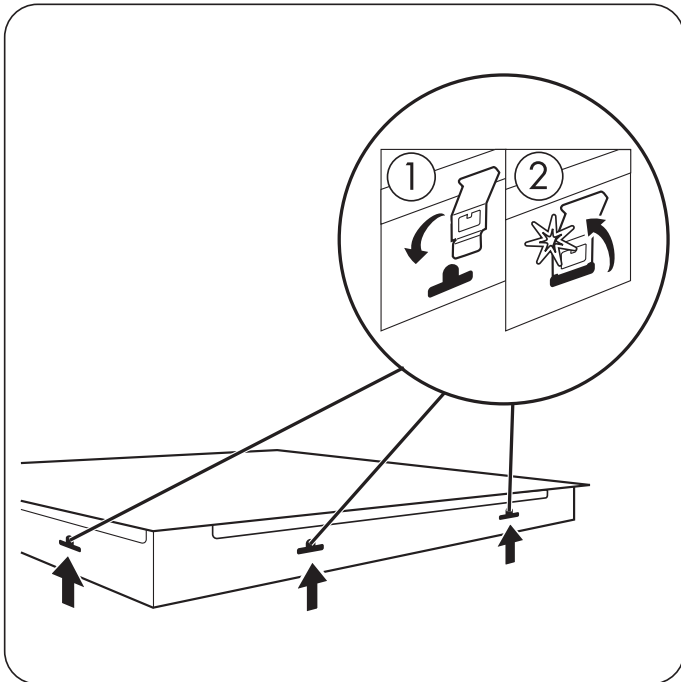

disposal



ENVIRONMENTAL TIPS

Packaging material

The packaging materials are environmentally friendly and can be recycled. The plastic components are identified by markings e.g. >PE<, >PS<, etc. Please dispose of the packaging materials in the appropriate container at the community waste disposal facilities.

Old appliance

The symbol  on the product or on its packaging indicates that this product may not be treated as household waste. Instead it shall be handed over to the applicable collection point for the recycling of electrical and electronic equipment. By ensuring this product disposed of correctly, you will help prevent potential negative consequences for the environment and human health, which could otherwise be caused by inappropriate waste handling of this product, please contact your local city office, your household waste disposal service of the shop where you purchased the product.

technical data

MODEL	CHC644BB
PNC	949163421
Product Dimensions (w x d) mm	590 x 520
Cut-out Dimensions (w x d) mm	560 x 490
Voltage (Volts)	220-240
Frequency (Hz)	50 - 60
Elements (Watts)	
Front left	2300
Rear Left	1200
Front Right	1200
Rear Right	1800
Total	6500

Electrolux Warranty

FOR SALES IN AUSTRALIA AND NEW ZEALAND
 APPLIANCE: CHEF BUILT-IN OVENS, COOKTOPS AND FREESTANDING
 COOKER

This document sets out the terms and conditions of the product warranties for Chef Appliances. It is an important document. Please keep it with your proof of purchase documents in a safe place for future reference should there be a manufacturing defect in your Appliance. This warranty is in addition to other rights you may have under the Australian Consumer Law.

1. In this warranty:

- (a) 'ACL' or 'Australian Consumer Law' means Schedule 2 to the Competition and Consumer Act 2010;
- (b) 'Appliance' means any Electrolux product purchased by you and accompanied by this document;
- (c) 'ASC' means Electrolux's authorised serviced centres;
- (d) 'Chef' is the brand controlled by Electrolux Home Products Pty Ltd of 163 O'Riordan Street, Mascot NSW 2020, ABN 51 004 762 341 in respect of Appliances purchased in Australia and Electrolux (NZ) Limited (collectively "Electrolux") of 3-5 Niall Burgess Road, Mount Wellington, in respect of Appliances purchased in New Zealand;
- (e) 'Warranty Period' means the period specified in clause 3 of this warranty;
- (f) 'you' means the purchaser of the Appliance not having purchased the Appliance for re-sale, and 'your' has a corresponding meaning.

2. Application: This warranty only applies to new Appliances, purchased and used in Australia or New Zealand and is in addition to (and does not exclude, restrict, or modify in any way) other rights and remedies under a law to which the Appliances or services relate, including any non-excludable statutory guarantees in Australia and New Zealand.

3. Warranty Period: Subject to these terms and conditions, this warranty continues in Australia for a period of 24 months and in New Zealand for a period of 24 months, following the date of original purchase of the Appliance.

4. Repair or replace warranty: During the Warranty Period, Electrolux or its ASC will, at no extra charge if your Appliance is readily accessible for service, without special equipment and subject to these terms and conditions, repair or replace any parts which it considers to be defective. Electrolux may, in its absolute discretion, choose whether the remedy offered for a valid warranty claim is repair or replacement. Electrolux or its ASC may use refurbished parts to repair your Appliance. You agree that any replaced Appliances or parts become the property of Electrolux.

5. Travel and transportation costs: Subject to clause 7, Electrolux will bear the reasonable cost of transportation, travel and delivery of the Appliance to and from Electrolux or its ASC. Travel and transportation will be arranged by Electrolux as part of any valid warranty claim.

6. Proof of purchase is required before you can make a claim under this warranty.

7. Exclusions: You may not make a claim under this warranty unless the defect claimed is due to faulty or defective parts or workmanship. This warranty does not cover:

- (a) light globes, batteries, filters or similar perishable parts;
- (b) parts and Appliances not supplied by Electrolux;
- (c) cosmetic damage which does not affect the operation of the Appliance;

- (d) damage to the Appliance caused by:
 - (i) negligence or accident;
 - (ii) misuse or abuse, including failure to properly maintain or service;
 - (iii) improper, negligent or faulty servicing or repair works done by anyone other than an Electrolux authorised repairer or ASC;
 - (iv) normal wear and tear;
 - (v) power surges, electrical storm damage or incorrect power supply;
 - (vi) incomplete or improper installation;
 - (vii) incorrect, improper or inappropriate operation;
 - (viii) insect or vermin infestation;
 - (ix) failure to comply with any additional instructions supplied with the Appliance;

In addition, Electrolux is not liable under this warranty if:

- (a) the Appliance has been, or Electrolux reasonably believes that the Appliance has been, used for purposes other than those for which the Appliance was intended, including where the Appliance has been used for any non-domestic purpose;
- (b) the Appliance is modified without authority from Electrolux in writing;
- (c) the Appliance's serial number or warranty seal has been removed or defaced

8. How to claim under this warranty: To enquire about claiming under this warranty, please follow these steps:

- (a) carefully check the operating instructions, user manual and the terms of this warranty;
- (b) have the model and serial number of the Appliance available;
- (c) have the proof of purchase (e.g. an invoice) available;
- (d) telephone the numbers shown below.

9. Australia: For Appliances and services provided by Electrolux in Australia: Electrolux goods come with guarantees that cannot be excluded under the Australian Consumer Law. You are entitled to a replacement or refund for a major failure and for compensation for any other reasonably foreseeable loss or damage. You are also entitled to have the Appliance repaired or replaced if the Appliance fails to be of acceptable quality and the failure does not amount to a major failure. 'Acceptable quality' and 'major failure' have the same meaning as referred to in the ACL.

10. New Zealand: For Appliances and services provided by Electrolux in New Zealand, the Appliances come with a guarantee by Electrolux pursuant to the provisions of the Consumer Guarantees Act, the Sale of Goods Act and the Fair Trading Act. Where the Appliance was purchased in New Zealand for commercial purposes the Consumer Guarantee Act does not apply.

11. Confidentiality: You accept that if you make a warranty claim, Electrolux and its agents including ASC may exchange information in relation to you to enable Electrolux to meet its obligations under this warranty.

Important Notice

Before calling for service, please ensure that the steps listed in clause 8 above have been followed.

AUSTRALIA	FOR SERVICE or to find the address of your nearest authorised service centre in Australia PLEASE CALL 13 13 49 <small>For the cost of a local call</small>	FOR SPARE PARTS or to find the address of your nearest spare parts centre in Australia PLEASE CALL 13 13 50 <small>For the cost of a local call</small>
NEW ZEALAND	FOR SERVICE or to find the address of your nearest authorised service centre in New Zealand PLEASE CALL 0800 10 66 10	FOR SPARE PARTS or to find the address of your nearest spare parts centre in New Zealand PLEASE CALL 0800 10 66 20

LIKE TO KNOW MORE?



Customer Care Centre

Contact us if you need more help

Australia

phone: 13 13 49

email: customercare@electrolux.com.au

website: chef.com.au

**WE ARE PART OF THE ELECTROLUX FAMILY.
TO ADD A TOUCH OF PROFESSIONAL INSPIRATION
TO YOUR HOME, VISIT ELECTROLUX.COM**

© 2020 Electrolux Home Products Pty Ltd
ABN 51 004 762 341
ANC : A05333008 Rev.A
C_MAN_CHC644_Nov20

